



# ELECTRIC CHAIN HOIST

# ED III SERIES SINGLE-PHASE

Compact!  
Light!  
Fast!



JAB  
ISO 9001  
ISO 14001

JMA  
ISO 9001  
ISO 14001

# SINGLE-PHASE AC120V or 240V(max)

Available to use at voltage range from 110 to 120V(max) or 220 to 240V(max).  
The lifting speed varies according to the decreasing of the voltage.

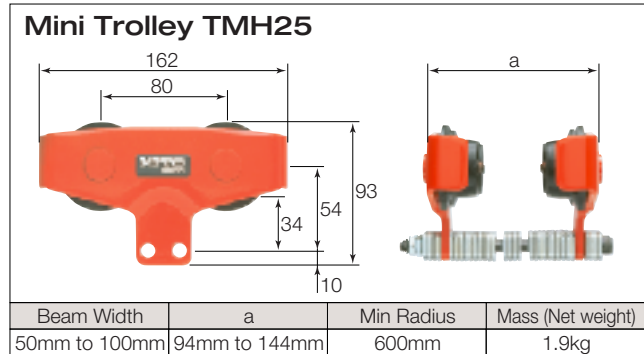
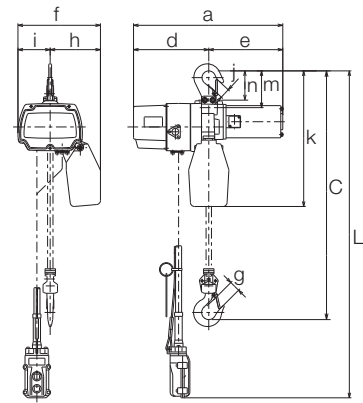
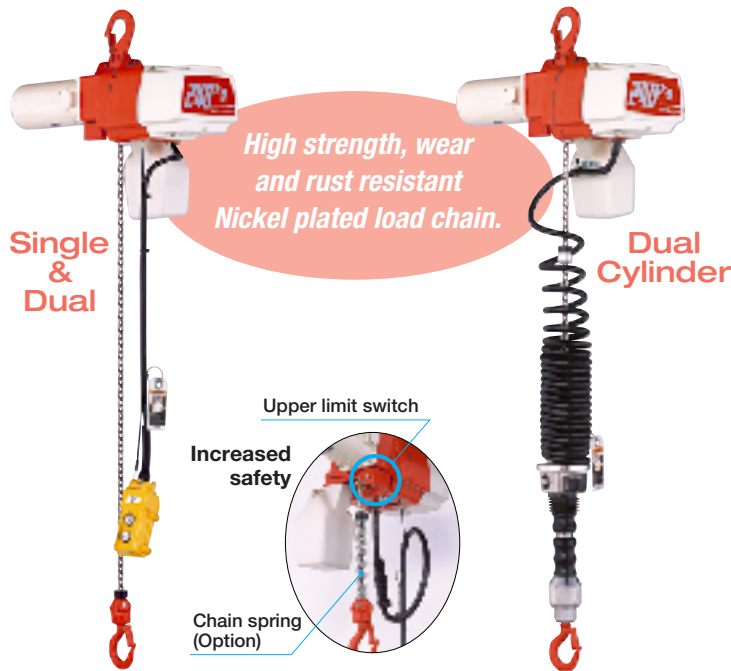

Power Supply		120V or 240V 50Hz/60Hz														
Type		Single speed type					Dual speed type					Dual Cylinder type				
Model		ED06S	ED10S	ED18S	ED16S	ED24S	ED06ST	ED10ST	ED18ST	ED16ST	ED24ST	EDC06SD	EDC10SD	EDC18SD	EDC16SD	EDC24SD
Rated load	(kg)	60	100	180	160	240	60	100	180	160	240	60	100	180	160	240
Motor output	(W)	300			600		300			600		300		600		
Time rating	(min)	15(20)		10(15)	20		15(20)		10(15)	20		15(20)		10(15)	20	
Intermittent duty	%ED	30		20	30		30		20	30		30		20	30	
	Max.start frequency (Times per hour)	180		120	180		180		120	180		180		120	180	
Rated Current	120V	5		6	10		5		6	10		5		6	10	
	240V	3		5		3		5		3		5		3		
Lifting Speed	High	21	13	8	20	13.5	21	13	8	20	13.5	21	13	8	20	13.5
	Low	—	—	—	—	—	4	3	3	4	3	4	3	3	4	3
Standard lift	(m)	3					3					1.8				
Push button cord length:	L(m)	2.5					2.5					—				
Load chain diameter	(mm)	4					4					4				
Mass (Net weight)	(kg)	11.5(12)*1			15.5(16)*1		12(12.5)*1			16(16.5)*1		14.5(15)*1		18.5(19)*1		
Min.distance between hooks:	C(mm)	315			330		315			330		945		960		
Dimension	a	371	(364)	428		371		(364)	428		371		(364)	428		
	d	187	205		187		205		187		205		187			
	e	184	(177)	223		184		(177)	223		184		(177)	223		
	f	205	219		205		219		205		219		205			
	h	125	135		125		135		125		135		125			
	i	80	84		80		84		80		84		80			
	g	25					25					25				
	j	25					25					25				
	k	340		362		340		362		340		362		340		
	m	92					92					92				
n	73					73					73					

- Control: Direct control is standard. Low voltage is available upon request. •Power supply cable: 2mm<sup>2</sup> x 3 core 5m with grounding wire.
- The lifting speed is equal to the average value of the lifting / lowering speed at the rated load capacity. The speed will vary according to the load.
- Figures in parentheses show the data for 240V(max). •\*1:Mass (Net weight) in parentheses are at control voltage 30V.

Specifications and dimensions are subject to change without notice.



**KITO** CORP

3-37-4 Yoyogi, Shibuya-ku, Tokyo 151-0053, Japan  
TEL: +81 3-5371-7341 FAX: +81 3-5371-7349  
E-mail: overseas@kito.co.jp  
URL http://www.kito.co.jp

Distributed by: