



Ultra Compact and Light.
Reliable load-holding performance.



KITO NEW POCKET-SIZED LEVER HOISTS LX SERIES LAUNCHED

KITO LEVER BLOCK™

LX Series 250kg/500kg



Special carrying case for LX003 (Option)

The LX003 fits comfortably in this stylish, black carrying case, which can be attached to your belt for enhanced convenience.

- Color: black
- Material: Polyester
- Size: approx. 170 x 120 x 55mm
- Has a belt loop and pocket
- KITO LX logo

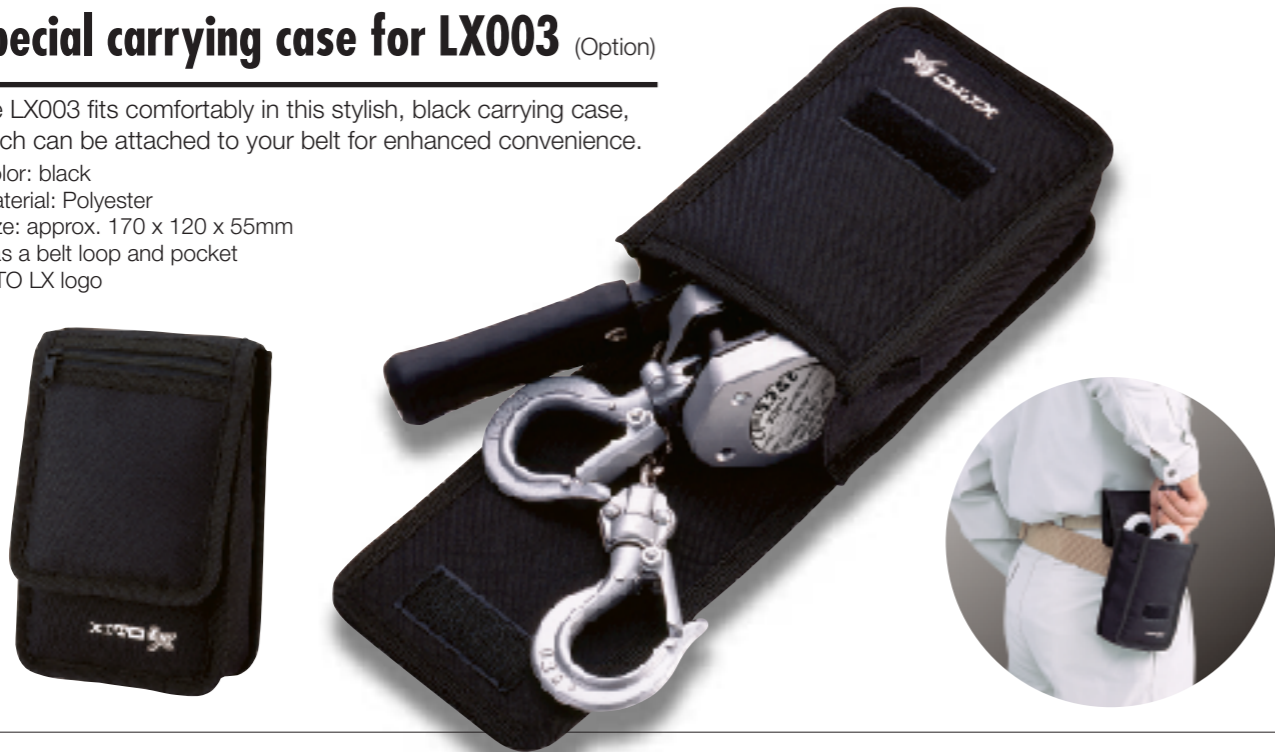

Features and performances of all the products described in this catalogue are designed for their own intended purposes.
KITO will not be held liable for any malfunction, lack of performance or accident if the product is being used in conjunction with any other equipment.
If the product is to be used for unintended purposes, please confirm with your dealer in advance.

All specifications herein are subject to change without notice.

Distributed by:



KITO CORP.

3-37-4 Yoyogi, Shibuya-ku, Tokyo 151-0053, Japan

TEL: +81 3-5371-7341 FAX: +81 3-5371-7349

E-mail: overseas@kito.co.jp

URL <http://www.kito.co.jp>



Printed in Japan 15.03(SA.H)LX02-05



**Extremely compact, lightweight, portable design for ease of use in elevated work positions.
Low hand-pull force for highly reliable pulling and lifting to the last click.**

Kito's original free chain adjusting mechanism

A required chain length is provided instantly with ease by simply turning the selector lever to "N (neutral)" position.

Net weight of just 1.6kg!
(LX003)

Lever length of just 150mm!
(LX003)

Reliable load-holding performance

The LX series, designed with a single-step reduction gear, is characterized by a small manual fastening force and assured load holding. Reliable load fastening can be provided to the last clicking of the lever.

Extremely compact and light

Kito's innovative technology makes the LX series extremely compact and light. It's very easy to carry, and easy to use, even in tight quarters or in elevated work locations. What's more, it can be conveniently stored in a special carrying case (LX003 only).

Maintainability

Fasteners are designed to protect threads from damage making maintenance easier.

Nickel-plated chain

Kito's unique R&D produces world-class performance. The grade 100(1000 N/mm²) chain, made from a special high strength alloy, features an unbeatable combination of toughness and resistance to corrosion & wear. (For special environments consult your Kito distributor since corrosion resistance varies depending on corrosives involved)

Minimum headroom (distance) between hooks: 205mm (LX003)

Hook latch with safety mechanism

The hook latch employs tip-supporting structure for guaranteed holding and is highly resistant to deformation and damage.

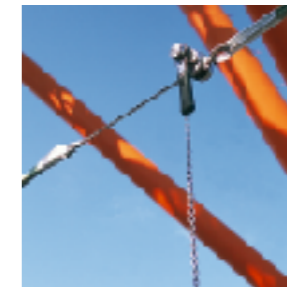
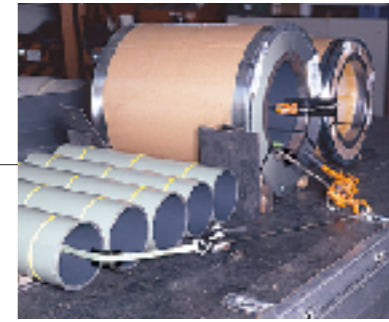

Perfect Fastening

KITO LEVER BLOCK™ LX Series 250kg/500kg

Two capacities available – the LX003 has a rated capacity of 250kg, and the LX005 has a rated capacity of 500kg.

Extremely compact & light, these LX series hoists are suitable for work in tight quarters or elevated locations where fastening, fixing, or positioning of light loads is required.

- Load fastening
- Tension
- Lifting/lowering
- Anchoring
- Positioning
- Distortion correction
- Alignment of structures
- Other load handling

Specifications and Dimensions

Rated load (W.L.L.)	(kg)	250	500
Code		LX003	LX005
Standard lift	(m)	1	1.2
Hand-pull to lift full load	(N)[kg]	200 [20]	310 [31]
Load Chain Diameter (mm) x Fall	(mm)	3.2x1	4.3x1
Test load	(kg)	380	750
Mass (Net weight)*	(kg)	1.6	2.6
Shipping weight (Approx.)	(kg)	1.8	2.8
Dimensions (mm)	a	85.5	99
	b	73.5	93
	C	205	246
	D	150	180
	e	60	67
	g	21	24.5
	s	32	35.5
	t	11	12

LX003

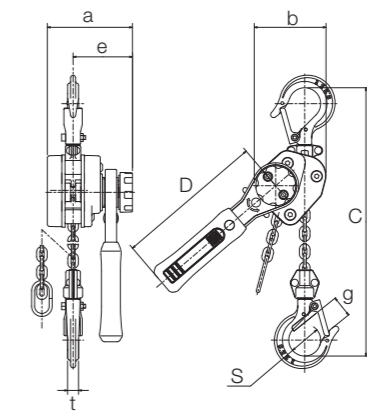

LX005

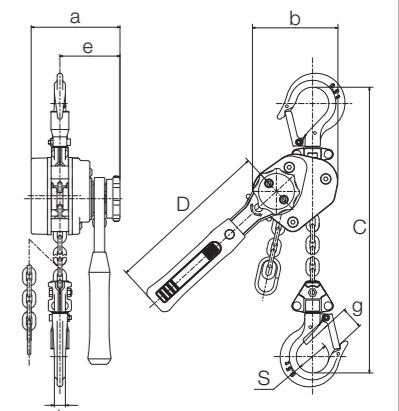

* The Mass (net weight) is for the standard load-lifting height.