



the Crosby group[®]

SAFETY ■ RELIABILITY ■ INNOVATION

Introduction

- Introduction
 - Company profile
 - Core competences
 - Market Segments
 - Feubo products
- Feubo products
 - Mooring accessories
 - Heavy lifting
- Round the world projects
- Feubo testing

theCrosbygroup[®]

SAFETY ■ RELIABILITY ■ INNOVATION



Crosby[®]

Company profile

- Feubo started to manufacture mooring hardware over 30 years ago
- Since 25 years Feubo is approved manufacturer of hardware for the offshore mooring industry
- Feubo designs unique products in the highest grade for special mooring applications
- Zero failure of Feubo LTM Hardware in service
- Feubo manufactures LTM sizes between 70 and 168 mm in R3 to R5 qualities

Core competences

Core competences

- Design
- R&D
- Certification of the design
- Certification of the production process
- Quality management:
 - from raw material to finished product
 - in every production step
- Final machining
- Inspection and testing to the class rules
- Product certification with class



Core competences

R&D and Quality Management

Data management and analysis

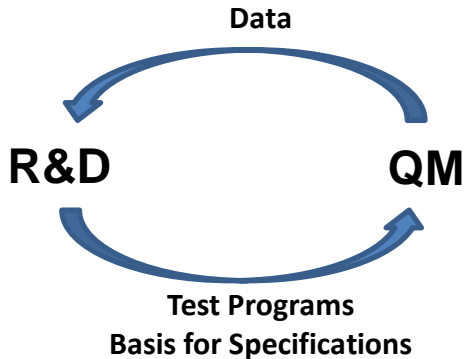

extern

- Specification to the sub-suppliers
- Process quality management
- Release of the raw material for the production steps at sub-supplier

intern

- Competence data base
- Standard material curves approved by Class
- Standardization of documentation
- Continuous improvement of design and production process

The result is high efficiency in guaranteeing the high quality of the product and customer satisfaction

Core competences

Design & FEA

- Advanced design and modelling programs maximize strength, minimize weight and increase utility
- FEA analysis optimizes design characteristics

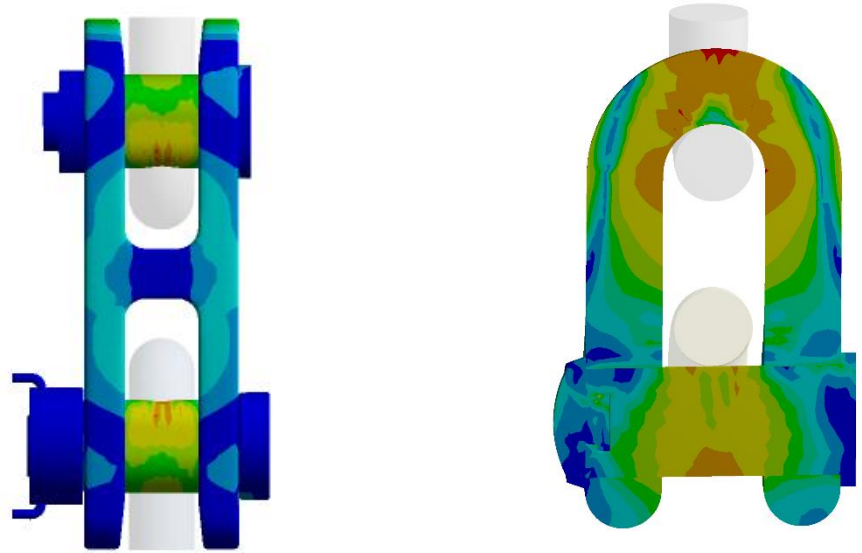

Core competences

Heat Treatment

- Fully automated heat treatment for maximum process control and best in industry repeatability
- This is in our view the only way to guarantee:
 - Consistency
 - Repeatability
 - Unmatched reproducibility of good quality results

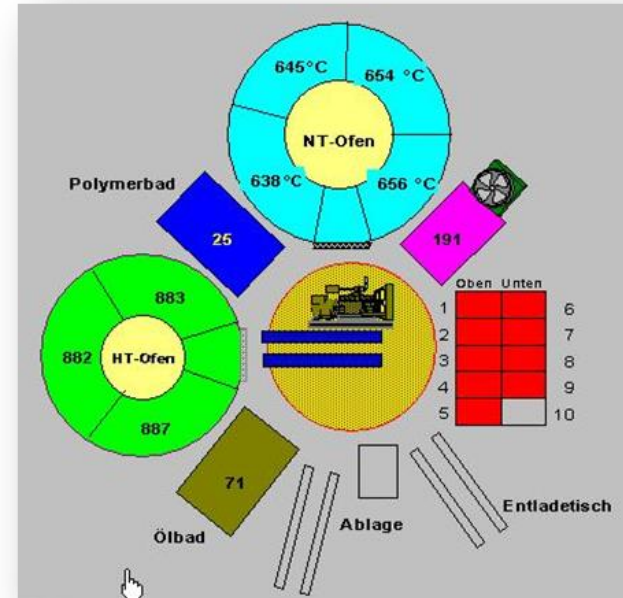

Core competences

Core competences

- Design
 - Precision German machining
 - CNC/DNC controlled



Core competences

Testing

- Total of 3 testing rigs
- 6000 mT
- 2000 mT
- 700 mT



Core competences

Testing

- Capacity of 6000 mT
- Largest class certified rig in Europe
- Calibrated by class



Core competences

Testing

- Dynamic Testing to 700 mT
- Total Load 700 mT
- Test Frequencies 0.3 – 3 Hz
- Calibration by MPA NRW
- Testing in Ambient Air
- Testing in low temps (-60°)
- Testing in sea water
(ASTM D1141-98)



Market segments

Upstream and Downstream activities in Oil and Gas Sector

Offshore drilling activities: MODUs, drillships



Offshore production activities: FPU, FPS, etc.



Market segments

Upstream and Downstream activities in Oil and Gas Sector

Offshore storage/offloading: FSO, FPSO, FSRU, etc.



Offshore terminal systems: SPM/CALM, CBM, etc.



Market segments

Offshore construction

Barges



Pipeline vessels



Market segments

Floating wind



Feubo products

Product range – all connectors in a Mobile/Temporary & Long Term Mooring systems

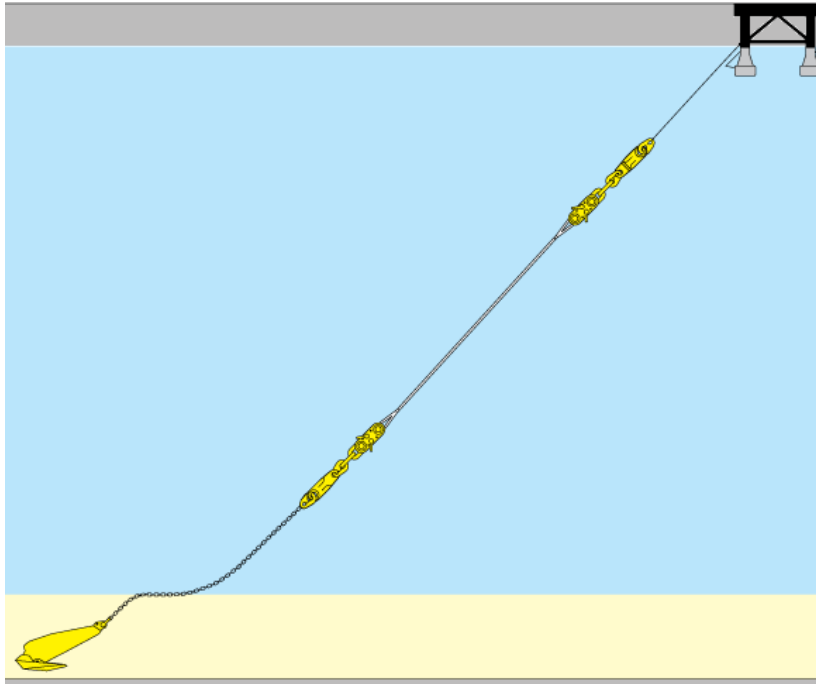

Products

- Kenter shackles - NDur
- Anchor shackles
- Swivels – Nautilus, etc..
- Shackles – Joining shackles, etc..
- Tri plates
- Chasers
- H-Links
- C-Links
- Sockets
- KS Hook
- [DOWNLOAD HERE THE CATALOGUE 2019](#)

Feubo products - Kenters



Kenter Joining Shackle



Raptor Anchor Shackle



NDur Link



Raptor Thin Shackle Fastlock



Trident Thin Shackle



Raptor Thin Shackle



NDur Anchor Shackle



Trident Anchor Shackle

Feubo products - C – Type connector



C-Type Connector



Pear Link



MARC
Modified Anchor Connect Link

Feubo products - Shackle



Anchor Shackle



Double Nut Shackle



Special D-Type Joining Shackle



End Joining Shackle



D-Type Joining Shackle



Anchor Pile Shackle

Feubo products - Link



H – Link



Hybrid H-Connector



Tri-Link Adapter



Hinge Link



Y-Connector



Chain Clamp

Feubo products - Link

ROV H link

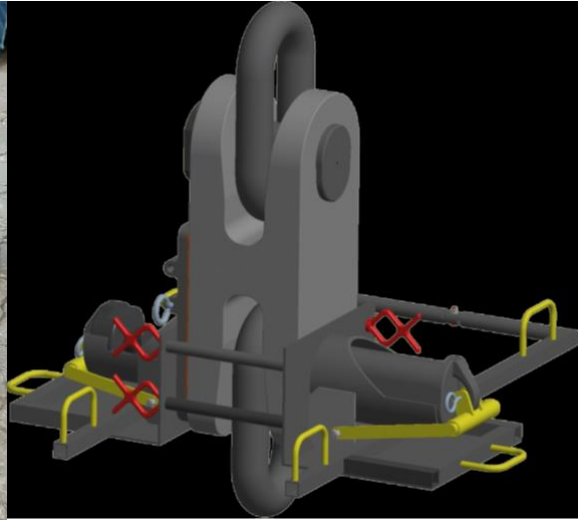
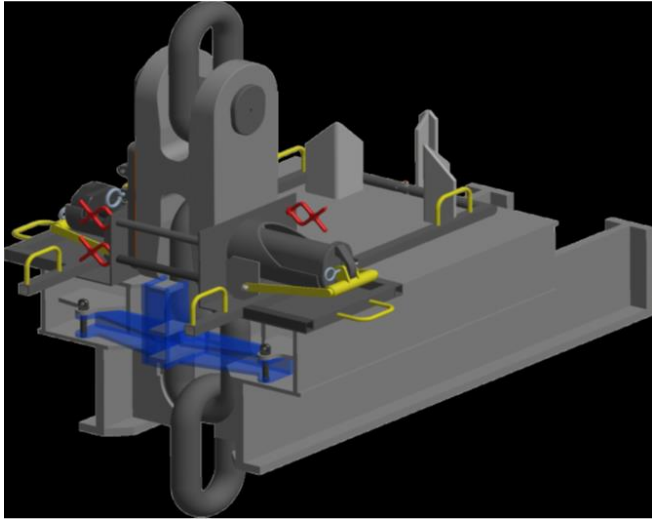

Feubo products - Plate



Delta Plate



Tri-Plate

Feubo products - Others



KS Hook



Roulette Thimble

Feubo products



KS Hooks:

- Ideal for quick connection and disconnection from pre-laid mooring systems.
- Closed die forged.
- DNV, ABS and BV – LTM Approvals
- May be used as an ROV Hook for synthetics.



Feubo products



Feubo references

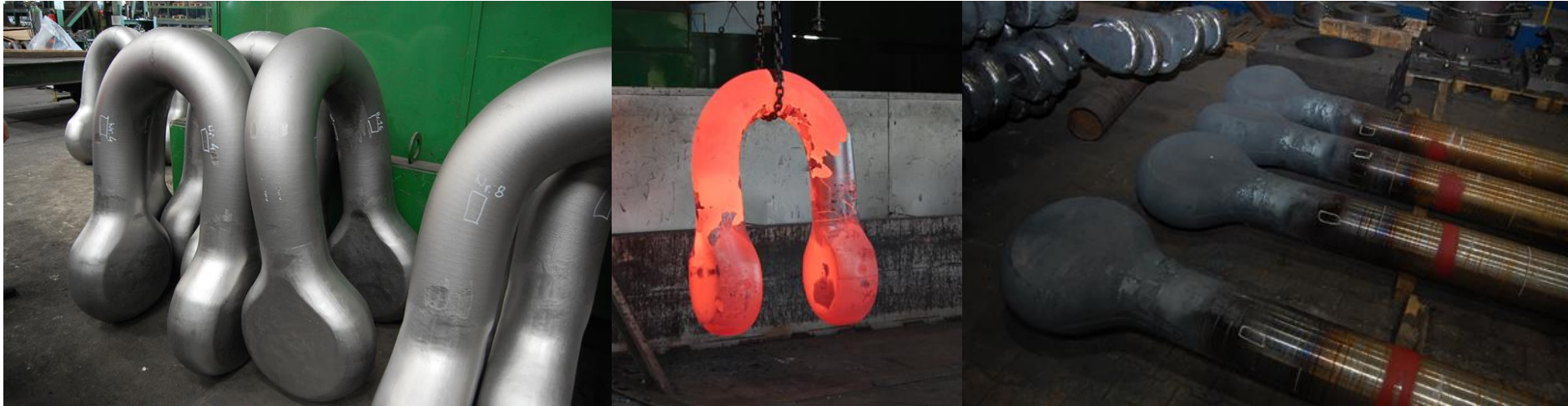

- Turnkey solution for SHELL Appomattox Shackle.
- 168mm Grade R4-S – Largest shackles ever made in this quality.

Feubo references

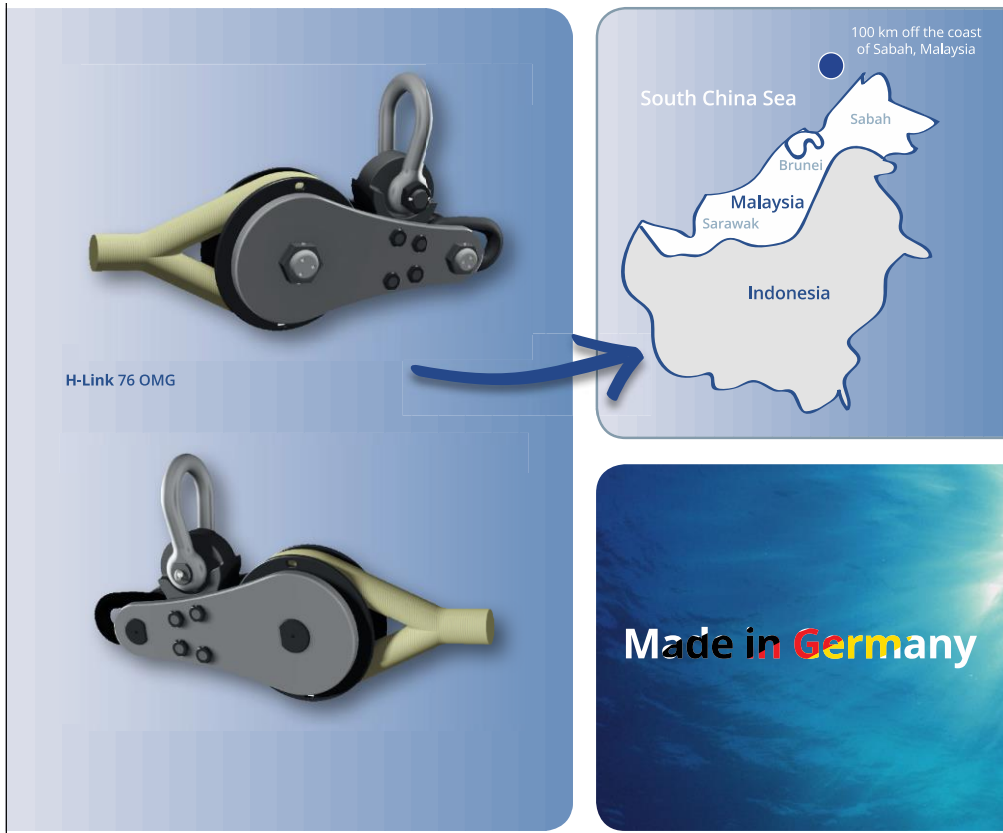

Malikai Tension Leg Platform (TLP)

Block G: Sabah, Malaysia

Shell: 35% Stake

ConocoPhillips: 35% Stake

Petronas: 30% Stake

80,000 Barrels a day

Water depth: 500 meters

Custom H Link for 76mm chain to Poly Rope with thimbles.

Feubo references

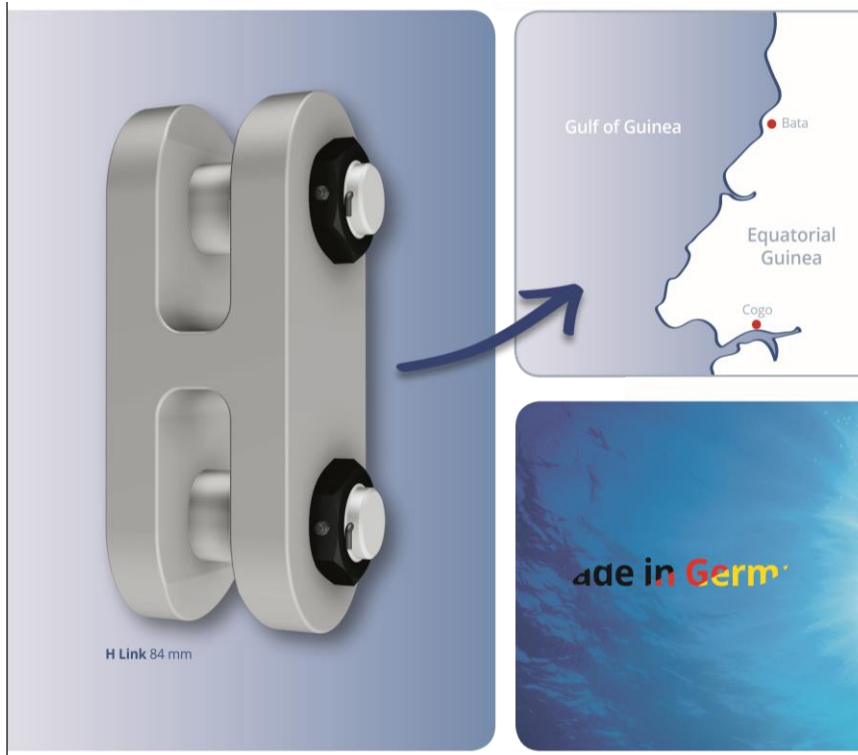

Sendje Ceiba

- Triton Energy and Energy Africa discovered the Ceiba field in October 1999.
- The Ceiba field is located 22 mi offshore Equatorial Guinea and was the first discovery in the Rio Muni Basin.
- Hess is the current operator of Blocks G and F with an 85% interest. Energy Africa holds 15% and the Equatorial Guinea government holds 5%.

Feubo references



FSO Rang Dong MV17

Block 15-2: Vung Tau, Vietnam

MODEC owns and operates FSO services for the Rang Dong field.

60,000 Barrels a day receiving
350,000 Barrels storage capacity.

Water depth: 60 meters

Externally moored turrent design by SOFEC.

Feubo references

FPSO Cidade de Marigaratiba MV24

FPSO Cidade de Itaguai MV26

FPSO Cidade de Caraguatatuba MV27

FPSO Cidade de Campos MV29

SBM OSX 2 Brazil

ExxonMobil Serpentina FPSO

Shell Malikai Deepwater Oilfield

SOFEC SEPOC

ExxonMobil Zafiro Producer FPSO

Shell Appomattox

Moho Nord TOTAL

Hess Tubular Bells

Juniper Offshore Gas Project

Suncor Terra Nova FPSO

Numerous Mooring components for Petrobras projects

Feubo
the strongest link,
in your supply chain